

FBM214b, HART® Communication Input Module



An FBM214b provides up to eight HART® input channels. HART inputs are electrically compatible with 4-20 mA signals, permitting the plant to upgrade the field devices without changing the control system.

OVERVIEW

The FBM214b HART Communication Input Module contains eight 4 to 20 mA individually isolated analog input channels. It supports any mix of standard 4-20 mA devices and HART devices.

The FBM214b serves as a HART communications field device host, enabling the Foxboro Evo™ system to request and receive two digital messages per second from the field device. The message pass-through capability can be used to support HART universal, common practice, and device-specific commands, but not the burst communication mode. These commands are implemented using the

Intelligent Field Device Configurator Foxcom™ and HART™ Protocols (IFDC — refer to PSS 21S-8A3 B3 for details).

The FBM214b provides individually isolated power supplies to power each of the eight channels.

Optionally, the channels for both of these modules can be powered by an external power supply. However, when a common external power supply is used with two or more channels, a Cable Balun module is required to prevent HART communication channel crosstalk.

FEATURES

Key features of the FBM214b module are:

- ▶ Eight analog input channels, each accepting one of the following inputs:
 - Standard 4 to 20 mA analog sensor signal
 - Digital HART Frequency Shift Keying (FSK) signal superimposed on a 4 to 20 mA analog input signal.
- ▶ FSK modem dedicated to each input channel for bi-directional digital communications with a HART field device
- ▶ Analog to digital conversion of each of the 4 to 20 mA input signals from the HART devices
- ▶ Support for the HART universal commands necessary to interface the field device with the Foxboro Evo system database
- ▶ Per channel galvanic isolation of each of the 8 input channels from each other, ground and module logic
- ▶ Rugged design suitable for enclosure in Class G3 (harsh) environments
- ▶ High accuracy achieved by sigma-delta data conversions for each channel
- ▶ Termination Assembly (TA) for locally or remotely connecting field wiring to the FBM214b
- ▶ Termination Assembly for per channel internally and/or externally loop powered transmitters.

STANDARD DESIGN

The FBM214b has a rugged extruded aluminum exterior for physical protection of the circuits. Enclosures specially designed for mounting the FBMs provide various levels of environmental protection, up to harsh environments per ISA Standard S71.04.

HIGH ACCURACY

For high accuracy, the module incorporates a Sigma-Delta converter which can provide new analog input values for each channel every 100 milliseconds.

VISUAL INDICATORS

Light-emitting diodes (LEDs) incorporated into the front of the module provide visual indication of the module's operational status, and communication activity on the channels.

EASY REMOVAL/REPLACEMENT

The module can be removed/replaced without removing field device termination cabling, power, or communications cabling.

FIELDBUS COMMUNICATION

A Fieldbus Communication Module or a Control Processor interfaces the redundant 2 Mbps module Fieldbus used by the FBMs. The FBM214b module accepts communication from either path (A or B) of the redundant 2 Mbps fieldbus – should one path fail or be switched off at the system level, the module continues communication over the active path.

The use of an external power supply common to two or more loops requires a Cable Balun Module to maintain communication signal line balance.

MODULAR BASEPLATE MOUNTING

The module mounts on a modular baseplate which accommodates up to four or eight FBMs. The modular baseplate is either DIN rail mounted or rack mounted, and includes signal connectors for redundant fieldbus, redundant independent DC power, and termination cables.

TERMINATION ASSEMBLIES

Field input signals connect to the FBM subsystem via DIN rail mounted TAs. The TA used with the FBM214b is described in “TERMINATION ASSEMBLIES AND CABLES” on page 9.

CABLE BALUN MODULE

The Cable Balun module is used to maintain digital communication line balance for HART Transmitter to FBM loops that are powered from a common external power supply. This powering effectively connects one line of each loop together. Without the Baluns, in each loop so powered, the common connection at the external power supply, would cause near end crosstalk at the system end of the loop wiring cable. Loops using FBM internal power source do not require Baluns.

The Cable Balun module contains multiple Baluns. One Balun segment is interconnected in each loop powered from an external power supply per the diagram below. There is one Cable Balun module for four channels.

Cable Balun Module

Module Model	Module Part No.	No. of Baluns in the Module
CBM-4	RH903SV (supersedes P0903SV)	4

See Figure 1.

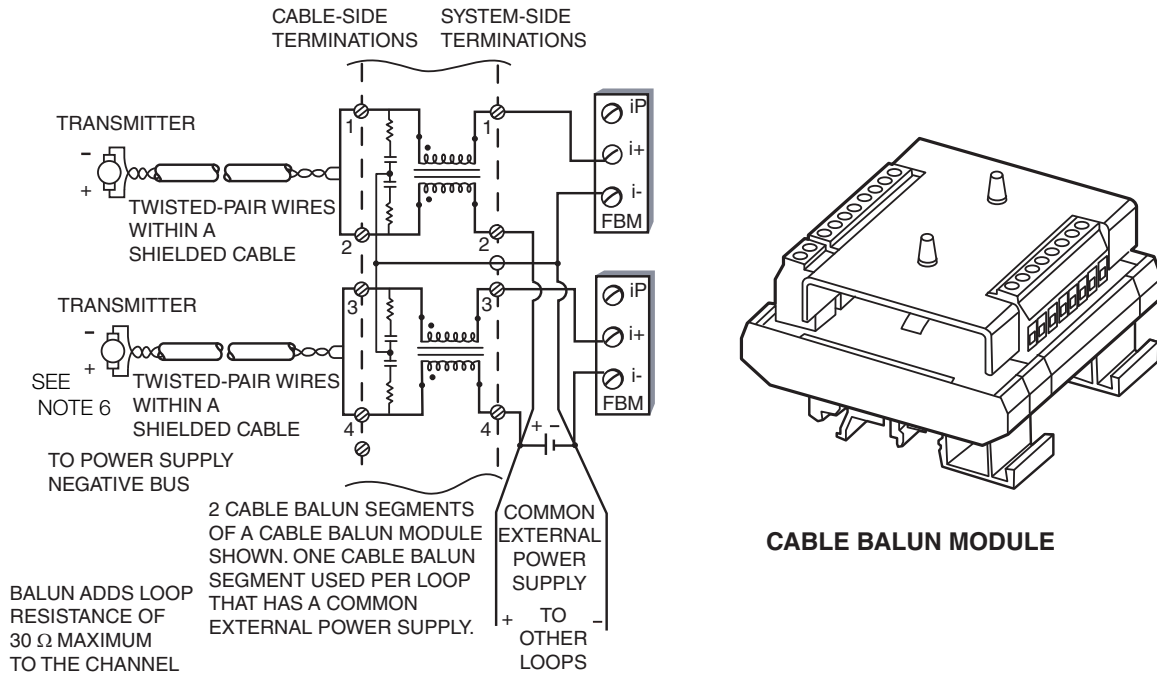

NOTES:

1. For detailed information on balun use and installation, refer to "Using the Cable Balun Module with Intelligent Transmitters" in *System Equipment Installation* (B0193AC).
2. Cable balun used only when multiple loops are connected to a common power supply. The FBM negative terminals connect directly to the minus (-) terminal of the power supply. The balun system side negative (-) terminals (2, 4, 6, and 8) connect to the power supply positive terminals when there are 4 (maximum) power loops.
3. For hazardous environments, install an intrinsic safety barrier such as an MTL 787S+ between the balun wiring to limit the amount of energy in the wiring.
4. A user-supplied capacitor can be installed across the external power supply(ies) to shunt AC power.
5. The external power supply can be redundant power supplies in parallel.
6. For this transmitter connection, use twisted-pair wiring inside a shielded cable with the shield grounded at the Foxboro Evo system end.

Figure 1. Cable Balun Module

FUNCTIONAL SPECIFICATIONS

Field Device Channels

SUPPORTED HART INSTRUMENT TYPES

HART instruments compliant to Version 5, 6, or 7 of the HART specifications may be used.

INTERFACE

8 individually isolated channels

COMMUNICATION TO THE DEVICE

Point-to-point, master/slave, asynchronous, half-duplex, at 1200 baud.

ERROR CHECKING

Parity on each byte, and one CRC check byte.

SPEED

2 messages per second

FASTEST ALLOWED ECB BLOCK PERIOD

100 msec - However, it is recommended that you refer to the *Sizing Guidelines and Excel Workbook* appropriate for your Control Processor to determine the optimal loading for a 100 msec Block Processing Cycle (BPC).

MAXIMUM DISTANCE (FBM214b TO FIELD DEVICE)

Meets HART FSK physical layer specification HCF_SPEC-54, Revision 8.1 [up to 3030 m (10000 ft)]⁽¹⁾.

INTERNAL LOOP SUPPLY COMPLIANCE VOLTAGE AT TERMINATION ASSEMBLY

18.5 V DC minimum at 20.5 mA

CURRENT INPUTS

Sense Resistor

61.5 Ω nominal

Total Input Resistance

280 Ω nominal

Accuracy (Includes Nonlinearity)

$\pm 0.03\%$ of full scale

Temperature Coefficient

50 ppm/ $^{\circ}\text{C}$

Resolution

15 bits

Update Rate

100 ms

Integration Time

500 ms

Common Mode Rejection

>100 db at 50 or 60 Hz

Normal Mode Rejection

>35 db at 50 or 60 Hz

INPUT RESISTANCE INCLUDING TERMINATION ASSEMBLY

Externally Powered

282 Ω

Internally Powered

302 Ω

LOOP POWER SUPPLY PROTECTION

The FBM214b provides an individually isolated current limited loop supply for each channel. All input loop supplies are limited by design to less than 37 mA.

FBM INTERNAL POWER FOR FIELD DEVICE

Per channel isolated 24 V DC $\pm 10\%$ supply. Loop supply output impedance is 20 Ω including the termination assembly.

I/A SERIES®/CONTROL CORE SERVICES

Requires I/A Series software v8.2 to v8.8 or Control Core Services software v9.0 or later.

(1) The maximum allowable distance decreases when the loop is operated through an intrinsic safety barrier. The maximum distance of the field device from the FBM is a function of compliance voltage, wire gauge and voltage drop at the device.

FUNCTIONAL SPECIFICATIONS (CONTINUED)

ISOLATION

The individual channel inputs and loop supplies are galvanically isolated from each other, ground and module logic.

The module's isolation is designed to withstand, without damage, a common mode potential of 600 V AC applied for one minute between the isolated input circuits and earth (ground), or between a given channel and any other channel.

CAUTION

This does not imply that these channels are intended for permanent connection to voltages of these levels. Exceeding the limits for input voltages, as stated elsewhere in this specification, violates electrical safety codes and may expose users to electric shock.

Fieldbus Communication

Communicates with its associated FCM or FCP via the redundant 2 Mbps module Fieldbus

Power Requirements

INPUT VOLTAGE RANGE (REDUNDANT)

24 V DC +5% -10%

CONSUMPTION

7 W (maximum)

HEAT DISSIPATION

4 W (maximum)

Regulatory Compliance

ELECTROMAGNETIC COMPATIBILITY (EMC)

European EMC Directive 2004/108/EC (Prior to April 20, 2016) and 2014/30/EU (Beginning April 20, 2016)

Meets: EN61326-1:2013 Class A Emissions and Industrial Immunity Levels

RoHS COMPLIANCE

Complies with European RoHS Directive 2011/65/EU

PRODUCT SAFETY (FBM AND CABLE BALUN)

Underwriters Laboratories (UL) for U.S. and Canada

UL/UL-C listed as suitable for use in UL/UL-C listed Class I, Groups A-D; Division 2; temperature code T4 enclosure based systems when connected to specified Foxboro Evo processor modules as described in the *Standard and Compact 200 Series Subsystem User's Guide* (B0400FA). Communications circuits also meet the requirements for Class 2 as defined in Article 725 of the National Electrical Code (NFPA No.70) and Section 16 of the Canadian Electrical Code (CSA C22.1). Conditions for use are as specified in the *Standard and Compact 200 Series Subsystem User's Guide* (B0400FA).

European Low Voltage Directive 2006/95/EC (Prior to April 20, 2016) and 2014/35/EU (Beginning April 20, 2016) and Explosive Atmospheres (ATEX) directive 94/9/EC (Prior to April 20, 2016) and 2014/34/EU (Beginning April 20, 2016)

DEMKO certified as Ex nA IIC T4 for use in certified Zone 2 enclosure when connected to specified I/A Series processor modules as described in the *Standard and Compact 200 Series Subsystem User's Guide* (B0400FA). Also, see Table 1 on page 10.

MARINE CERTIFICATION

(FBM214b only)

ABS Type Approved and Bureau Veritas Marine certified for Environmental Category EC31.

Calibration Requirements

Calibration of the module or termination assembly is not required.

ENVIRONMENTAL SPECIFICATIONS⁽²⁾**Operating****TEMPERATURE***Module*

-20 to +70°C (-4 to +158°F)

Termination Assembly

-20 to +70°C (-4 to +158°F)

RELATIVE HUMIDITY

5 to 95% (noncondensing)

ALTITUDE

-300 to +3,000 m (-1,000 to +10,000 ft)

Storage**TEMPERATURE**

-40 to +70°C (-40 to +158°F)

RELATIVE HUMIDITY

5 to 95% (noncondensing)

ALTITUDE

-300 to +12,000 m (-1,000 to +40,000 ft)

Contamination

Suitable for use in Class G3 (Harsh) environments as defined in ISA Standard S71.04, based on exposure testing according to EIA Standard 364-65, Class III.

Vibration7.5 m/S² (0.75 g) from 5 to 500 Hz

(2) The environmental limits of this module may be enhanced by the type of enclosure containing the module. Refer to the applicable Product Specification Sheet (PSS) which describes the specific type of enclosure that is to be used.

PHYSICAL SPECIFICATIONS

Mounting

MODULE

FBM214b mounts on a modular baseplate. The baseplate can be mounted on a DIN rail (horizontally or vertically), or horizontally on a 19-inch rack using a mounting kit. Alternatively, the modules mount on a 100 Series conversion mounting structure. Refer to *Standard 200 Series Baseplates* (PSS 31H-2SBASPLT) or *100 Series Conversion Mounting Structures* (PSS 31H-2W8) for details.

TERMINATION ASSEMBLY

The TA mounts on a DIN rail and accommodates multiple DIN rail styles including 32 mm (1.26 in) and 35 mm (1.38 in).

Weight

MODULE

284 g (10 oz) approximate

TERMINATION ASSEMBLY

Compression

181 g (0.40 lb) approximate

Dimensions – Module

HEIGHT

102 mm (4 in)

114 mm (4.5 in) including mounting lugs

WIDTH

45 mm (1.75 in)

DEPTH

104 mm (4.11 in)

Dimensions – Termination Assembly

See page 12.

Part Numbers

FBM214b MODULE

RH927AH (supersedes P0927AH)

TERMINATION ASSEMBLIES

See “FUNCTIONAL SPECIFICATIONS – TERMINATION ASSEMBLIES” on page 9.

Termination Cables

CABLE LENGTHS

Up to 30 m (98 ft)

CABLE MATERIALS

Polyurethane or Low Smoke Zero Halogen (LSZH)

TERMINATION CABLE TYPE

Type 1 – See Table 2 on page 10.

CABLE CONNECTION – TA

FBM Baseplate End

37-pin D-subminiature

Termination Assembly End

25-pin D-subminiature

Field Termination Connections

COMPRESSION-TYPE ACCEPTED WIRING SIZES

Solid/Stranded/AWG

0.2 to 4 mm²/0.2 to 2.5 mm²/24 to 12 AWG

Stranded with Ferrules

0.2 to 2.5 mm² with or without plastic collar

TERMINATION ASSEMBLIES AND CABLES

Field input signals connect to the FBM subsystem via DIN rail mounted Termination Assemblies. The TA for the FBM214b is available in Polyamide (PA) material with compression screw terminations.

See the following “FUNCTIONAL SPECIFICATIONS – TERMINATION ASSEMBLIES” for the TAs used with the FBM214b.

The FBM214b provides sufficient loop resistance to allow use of the HART Hand-Held Terminal, or PC20 Intelligent Field Device Configurator (PSS 2A-1Z3 E).

A removable termination cable connects the DIN rail mounted TA to the FBM via a field connector on the baseplate in which the FBM is installed. Termination cables are available in the following materials:

- ▶ Polyurethane
- ▶ Low Smoke Zero Halogen (LSZH).

Termination cables are available in a variety of lengths, up to 30 meters (98 feet), allowing the Termination Assembly to be mounted in either the enclosure or in an adjacent enclosure. See Table 2 for a list of termination cables used with the TAs for the FBM214b.

FUNCTIONAL SPECIFICATIONS – TERMINATION ASSEMBLIES

FBM Type	Input Signal	TA Part Number	Termination	TA Cable	TA Certification
		PA ^(a)	Type ^(b)	Type ^(c)	Type ^(d)
FBM214b	8 input channels, 4 to 20 mA analog signal, alone or with HART signal superimposed	RH924JH (supersedes P0924JH)	C	1	1, 2

- (a) PA is Polyamide rated from -20 to +70°C (-4 to +158°F).
 (b) C = TA with compression terminals; RL = TA with ring lug terminals.
 (c) See Table 2 for cable part numbers and specifications.
 (d) See Table 1 for Termination Assembly certification definitions.

Table 1. Certification for Termination Assemblies

Type	Certification ^(a)
Type 1	TAs are UL/UL-C listed as suitable for use in Class I; Groups A-D; Division 2 temperature code T4 hazardous locations. They are DEMKO certified EEx nA IIC T4 for use in Zone 2 potentially explosive atmospheres.
Type 2	TAs are UL/UL-C listed as associated apparatus for supplying non-incendive field circuits Class I; Groups A-D; Division 2 hazardous locations when connected to specified 200 Series FBMs and field circuits meeting entity parameter constraints specified in <i>Standard and Compact 200 Series Subsystem User's Guide</i> (B0400FA). They are also DEMKO certified as associated apparatus for supplying field circuits for Group IIC, Zone 2 potentially explosive atmospheres. Field circuits are also Class 2 limited energy (60 V DC, 30 V AC, 100 VA or less) if customer-supplied equipment meets Class 2 limits.

(a) All TAs are UL/UL-C listed to comply with applicable ordinary location safety standards for fire and shock hazards. Hazardous location types comply with ATEX directive for II 3 G use. They also comply with the requirements of the European Low Voltage Directive. All listings/certifications require installation and use within the constraints specified in *Standard and Compact 200 Series Subsystem User's Guide* (B0400FA) and the conditions stated in UL and DEMKO reports.

Table 2. Cables Types and Part Numbers

Cable Length m (ft)	Type 1 P/PVC ^(a)	Type 1 LSZH ^(b)
0.5 (1.6)	RH916DA (supersedes P0916DA)	RH928AA (supersedes P0928AA)
1.0 (3.2)	RH916DB (supersedes P0916DB)	RH928AB (supersedes P0928AB)
2.0 (6.6)	RH931RM (supersedes P0931RM)	RH928AC (supersedes P0928AC)
3.0 (9.8)	RH916DC (supersedes P0916DC)	RH928AD (supersedes P0928AD)
5.0 (16.4)	RH916DD (supersedes P0916DD)	RH928AE (supersedes P0928AE)
10.0 (32.8)	RH916DE (supersedes P0916DE)	RH928AF (supersedes P0928AF)
15.0 (49.2)	RH916DF (supersedes P0916DF)	RH928AG (supersedes P0928AG)

Table 2. Cables Types and Part Numbers (Continued)

Cable Length m (ft)	Type 1 P/PVC(a)	Type 1 LSZH (b)
20.0 (65.6)	RH916DG (supersedes P0916DG)	RH928AH (supersedes P0928AH)
25.0 (82.0)	RH916DH (supersedes P0916DG)	RH928AJ (supersedes P0928AJ)
30.0 (98.4)	RH916DJ (supersedes P0916DJ)	RH928AK (supersedes P0928AK)

(a) P/PVC is polyurethane outer jacket and semi-rigid PVC primary conductor insulation.

(b) Low smoke zero halogen or low smoke free of halogen (LSZH) is a material classification used for cable jacketing. LSZH is composed of thermoplastic or thermoset compounds that emit limited smoke and no halogen when exposed to high sources of heat. Temperature range; -40 to +105°C (-40 to +221°F)

Use of Termination Assemblies in 100 Series Upgrade Subsystem

When an FBM214b is used to replace a 100 Series FBM01 (connected to a HART device), the FBM214b may use the RH924JH (supersedes P0924JH) termination assembly for the FBM01's field I/O wiring.

Alternatively, the FBM214b can accept this field wiring through a Termination Assembly Adapter (TAA) instead of a termination assembly. This is discussed in *Termination Assembly Adapter Modules for 100 Series Upgrade* (PSS 31H-2W4).

DIMENSIONS – NOMINAL

[mm]
in

Compression Termination Assembly - RH924JH (supersedes P0924JH)

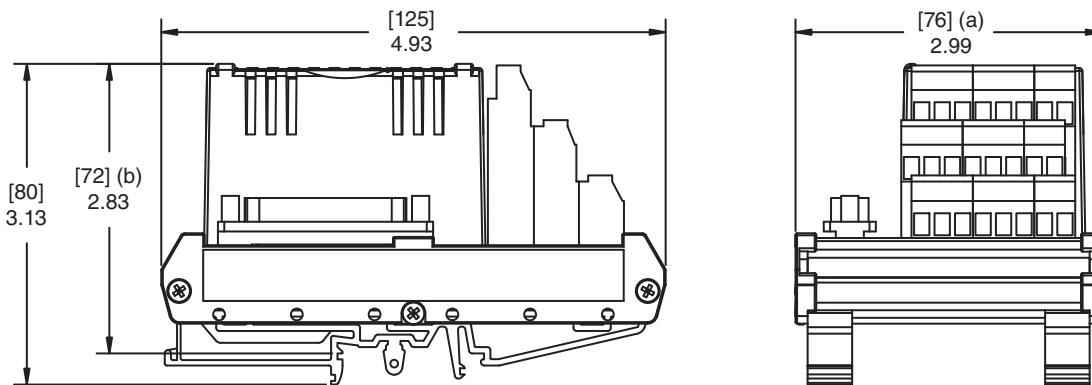

- (a) Overall width – for determining DIN rail loading.
- (b) Height above DIN rail (add to DIN rail height for total).

RELATED PRODUCT SPECIFICATION SHEETS

PSS Number	Description
PSS 31H-2SOV	Standard 200 Series Subsystem Overview
PSS 31H-2W100	100 Series Fieldbus Module Upgrade Subsystem Overview
PSS 31H-2CERTS	Standard and Compact 200 Series I/O, Agency Certifications
PSS 31H-2W4	Termination Assembly Adapter Modules for 100 Series Upgrade
PSS 31H-2SBASPLT	Standard and Compact 200 Series Modular Baseplates
PSS 31H-2W8	100 Series Conversion Mounting Structures
PSS 21S-3CP270IC	Control Processor 270 (CP270) Integrated Control Software
PSS 31S-3FCPICS	Field Control Processor 280 (CP280) Integrated Control Software

Foxboro[®]
by Schneider Electric

Invensys Systems, Inc.
38 Neponset Avenue
Foxborough, MA 02035-2037
United States of America
www.schneider-electric.com

Global Customer Support
Inside U.S.: 1-866-746-6477
Outside U.S.: 1-508-549-2424
Website: <https://support.ips.invensys.com>

Copyright 2015-2016 Invensys Systems, Inc.
All rights reserved.
Invensys is now part of Schneider Electric.

Schneider Electric, Invensys, Foxboro, and Foxboro Evo are trademarks owned by Schneider Electric SE, its subsidiaries and affiliates.
All other trademarks are the property of their respective owners.

MB 031

0816